



**QUICK REFERENCE GUIDE**  
for the  
**BITE 2P**  
**P/N 246004**

The instructions on this quick reference guide are intended as a reference only. Users or potential users of equipment manufactured by Megger are strongly advised to thoroughly read the accompanying instruction manual (AVTM246004) before attempting to operate the equipment. Failure to adhere to all of the safety precautions and the installation and operating instructions may result in personal injury or loss of life.

*Copyright © 2011 by Megger. All rights reserved.*

This document is proprietary to Megger. This document cannot be copied or reproduced in whole or in part, nor can its contents be revealed in any manner or to any person except to meet the purpose for which it was delivered, without the express written permission of Megger.

The information contained in this manual is subject to change. Revisions and updates will be issued from time to time to document changes and/or additions.

USA

Megger  
Valley Forge Corporate Center  
PO Box 9007  
Valley Forge, PA 19485-1007  
Telephone: 610-676-8500  
Fax: 610-676-8610  
[www.avointl.com](http://www.avointl.com)  
[battery@avointl.com](mailto:battery@avointl.com)

England

Megger  
Archcliffe Road  
Dover Kent CT17 9EN  
England  
Telephone: 44 (0) 1304 502101  
Fax: 44 (0) 1304 207342

1. Set up the Receiver first.
2. Turn on the unit. A series of messages flashes across the screen.
3. The display stops at WAND “Y or N.” If you bar-code, press the “▲” button and enter the necessary data for site, cell and ambient temperature. If you do not bar-code, press the “▼” button.
4. The display stops at ENTER BASELINE “Y or N.” If you want to enter a baseline value, press the “▲” button and enter the value by scrolling to enter 0 to 9 plus the decimal point using the “▲” and/or the “▼” buttons. Use the <Enter> key to move to the next character. It will ask for a warning level in percent change from the baseline then a fail level.
5. The display then stops at SPLIT STRAP “Y or N.” If your test current path is split among a number of straps, press “Y.” Enter the number of parallel paths and save (scroll through the # with the <Enter> key. Press <Enter> again to confirm). If your test current path involves only one strap, press “▼”.
6. The display will ask if you wish to SAVE SETTINGS “Y or N”. If no, then it will return to ENTER BASELINE “Y or N”. If you are satisfied with the entries, press the “▲” key.
7. The display tells you to connect the “CT”, then measure the RIPPLE CURRENT flowing in the battery circuit. To store the ripple current measurement, pull the trigger.
8. The display reads CONNECT & POWER TRANSMITTER.
9. Connect the transmitter to line power and turn on switch, S1.
10. Connect all leads, red to the (+) bus and black to the (-) bus.  
**For consistent results, make the current source lead connections to the cable, lug or terminal plate that connects to the battery terminals.**
11. Press the “Current On/Off” switch. After a short delay, the Current Ready lamp lights and the LCD displays the magnitude of current applied across the battery system.
12. The Receiver display will show the total test and ripple currents flowing in the battery circuit. Pull the trigger to save the total test current measurement.

13. The first line of the display shows 001 and the actual current level in the battery string. If the test current is outside the test limits, the display shows Lo / Hi. The second line shows TEST NUMBER 001, 002, etc.
14. Position the Receiver at the (+) post of the #1 cell, and the small probe at the (-) post of the #1 cell.
15. The display shows the (+) cell voltage and the impedance measurement. Pull the trigger to store the data.
16. For a moment the display will show the status of the cell compared to the baseline value, if entered.
17. The second line of the display shows STRAP. Move the Receiver to the (+) post of the next cell. The second display line shows the strap impedance. Pull the trigger. The beeper sounds and the readings are stored.
18. The display advances to cell number (n+1). Repeat steps 14 through 17 until all cells are measured. After every fourth cell, the amount of memory remaining in the Receiver is displayed.
19. After all the cells are measured, “short” the probe ends and pull the trigger. This creates a false strap measurement, which completes the last line of data. If this is not done, the impedance, V DC, and strap resistance for the last cell will be lost.
20. Arrow key Up to review data, or arrow key Down to end the test sequence. When the display shows an action message, stop and follow the instructions.
21. At this point, you may either close the test or print the active test to review the stored data. If the test is closed, no further testing/retesting can be performed on that test.
22. Disconnect “CT” and probe, and turn off transmitter. Disconnect current source injection leads.
23. To print the data on the BITE 2P transmitter printer, connect the data transfer cable to “J3- RS232” port on the Receiver and connect to “J3 – printer” port on the transmitter. The Receiver will prompt you for actions. All tests may be printed or only selected test(s) may be printed.
24. To transfer data to the laptop computer, connect the data transfer cable to the INPUT port on the computer and the “J3 - RS232” port on the Receiver.

25. The computer must be set to “download data from the Receiver.” PowerDB must be loaded on the computer before you perform this task. See the PowerDB instruction manual.
26. To complete the transfer, press “▲” for EBITE/PC on the Receiver, then press “▼” for PC. PLEASE WAIT appears in the display. When transfer is completed, the display changes to POWER DOWN or EXPORT DATA.

### 1. Turn on the Receiver.

- Connect "CT" to strap in battery string.
- Measure and save "ripple current".

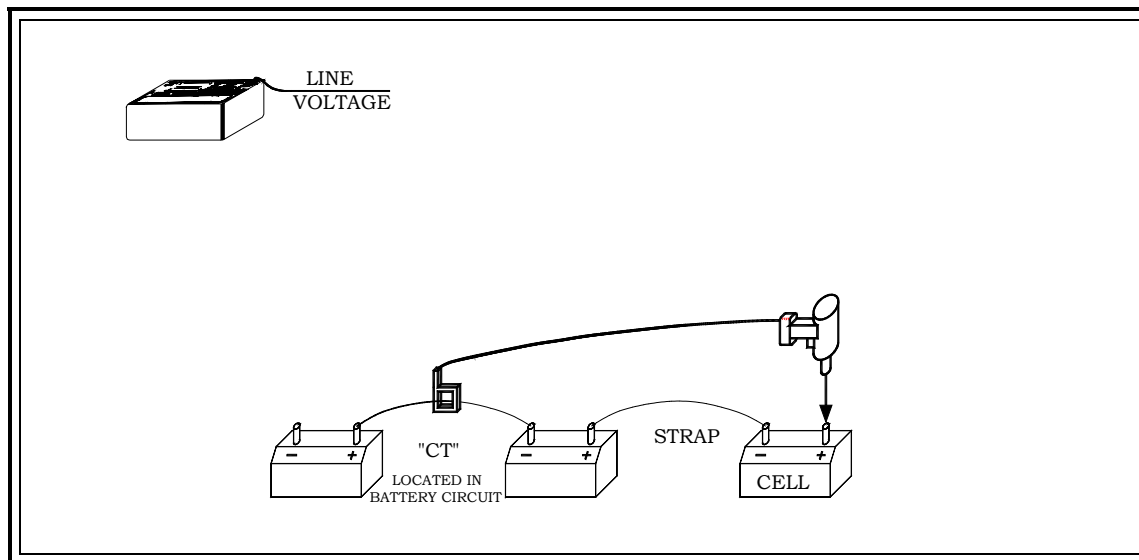

### 2. Connect the current source leads to the cables that connect to the battery terminals.

- Turn on transmitter – Measure and save the total test current.

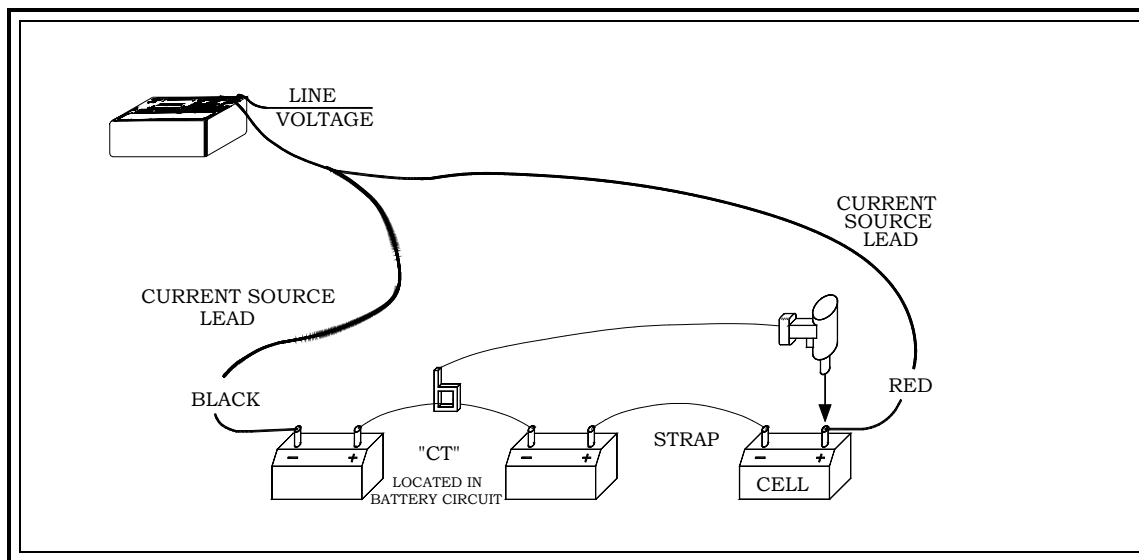

### 3. Cell Impedance

- Connect Receiver to (+) terminal and small probe to (-) terminal, pull the trigger to save the reading.

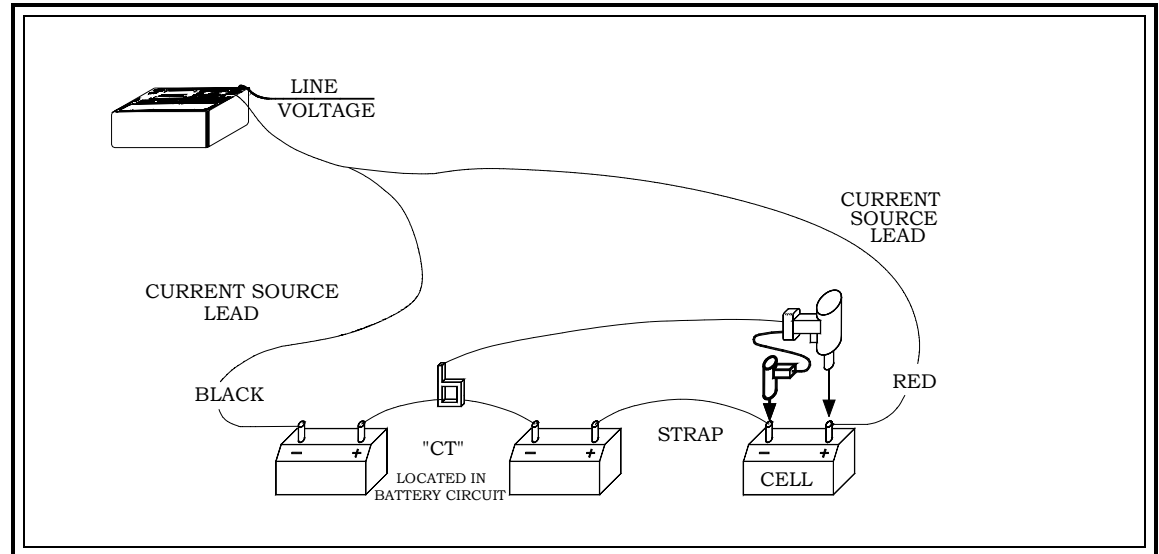

### 4. Strap Resistance

- Move the Receiver to the (+) terminal of the next cell. Pull the trigger to save the reading.

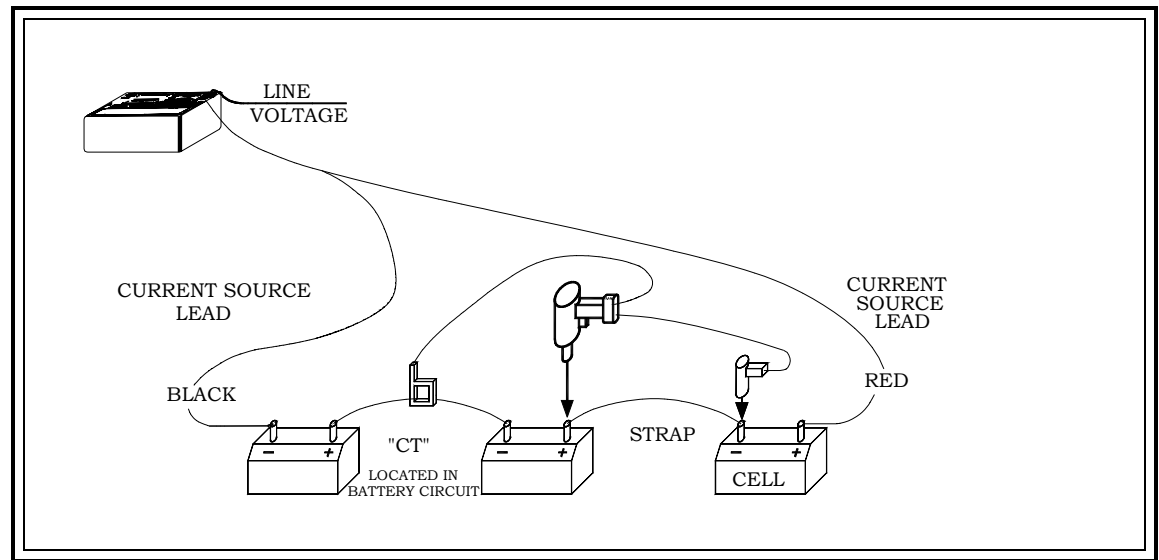

**5. Repeat Steps 3 and 4 until last cell is tested.**

- To save the last line of data, “short” probes together.
- Pull trigger to save the data.

**6. As needed, scroll up to review data or revise entries.**

**Scroll down to end test, then follow instructions to export data.**

**7. To print, connect the data transfer cable to “J3-RS232” port on the Receiver and connect to “J3 - printer” port on the transmitter.**

**8. Transfer data to laptop via cable supplied with the unit.**

**PowerDB must be installed in the laptop to make the transfer.**

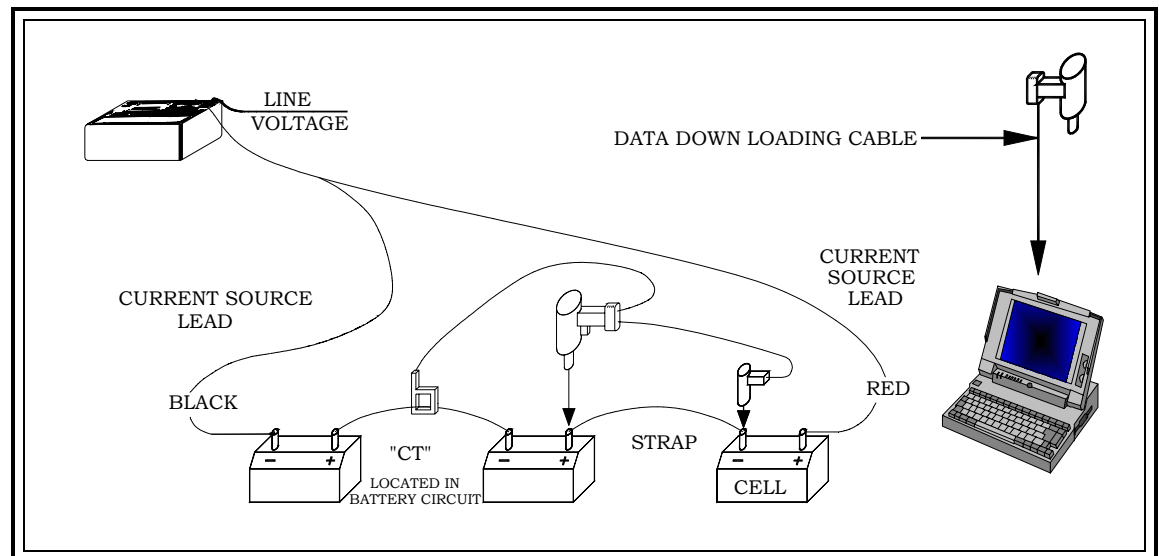

**Quick Reference Guide**  
**BITE 2P**

AVTM246004G-F  
Revised Dec. 2000  
Page 8 of 8

**Megger**<sup>®</sup>